



**DO NOT RETURN TO
STORE!**

CALL US FIRST!

**CUSTOMER HOTLINE
1-888-895-4549
FOR QUESTIONS OR
SERVICE INFORMATION**



**NE PAS RETOURNER AU
MAGASIN!**

APPELEZ-NOUS D'ABORD!

**ASSISTANCE TELEPHONIQUE
A LA CLIENTELE
1-888-895-4549
POUR L'INFORMATION DE
QUESTIONS OU SERVICE**



**NO LO DEVUELVA A LA
TIENDA!**

¡PRIMERO LLÁMENOS!

**LÍNEA DIRECTA DE ATENCIÓN
AL CLIENTE
1-888-895-4549
PARA LA INFORMACION de
PREGUNTAS O SERVICIO**



CAUTION

IMPORTANT - Please make certain that everyone who uses the Pro Force® Pressure Washer thoroughly reads and understands these instructions prior to operation.



ATTENTION

IMPORTANT - Veiller à ce que toute personne amenée à utiliser cet appareil de Pro Force® lise soigneusement ces instructions et les comprenne avant de procéder à son utilisation.



PRECAUCIÓN

IMPORTANTE - Favor de asegurarse de que toda persona que use el Lavador de presión Pro Force® lea y entienda todas las instrucciones antes de la operación.

TABLE OF CONTENTS

INTRODUCTION	3	OPERATING INSTRUCTIONS	7
CUSTOMER SERVICE	3	Start-up Procedure	7
SAFETY	3	Starting the Engine	7
Safety Symbols	3	CHEMICAL INJECTION	7
General Safety Precautions	4	CLEANING TECHNIQUES	8
SAFETY FEATURES	5	Application of Soap or Degreaser	8
Thermal Relief Valve	5	Application of Wax	8
Safety Lock Off Latch	5	END OF CLEANING OPERATION	8
Low Oil Shutdown	5	MAINTENANCE	8
Spark Arresting Muffler	5	Connections	8
SPECIFICATIONS	5	Nozzle	8
SPRAY NOZZLE SELECTION	5	Water Screen	8
BEFORE OPERATION	6	Engine Maintenance	8
Pre-Start preparation	6	STORAGE	9
Hose and Gun Assembly	6	Pump Storage	9
Lubrication	6	Engine Storage	9
Fuel	6	WARRANTY	9
ENGINE AND PUMP FEATURES	6	TROUBLESHOOTING	10
OPERATING CONNECTIONS	7	PARTS LIST AND PARTS DRAWING	28-31
High Pressure Hose	7		
Water Connection	7		

TABLE DES MATIÈRES

INTRODUCTION	11	UTILISATION	15
SERVICE CLIENTELE	11	Procédure de lancement	15
SÉCURITÉ	11	Mise en marche du moteur	15
Symboles utilisés	11	UTILISATION DE PRODUITS CHIMIQUES	15
Précautions Générales de Sécurité	12	TECHNIQUE DE NETTOYAGE	16
MESURES DE SÉCURITÉ	13	Application de Savon ou de Dégraissant	16
Soupape de surpression thermique	13	Application de Cire	16
Loquet de sécurité	13	FIN DE L'ACTIVITÉ DE NETTOYAGE	16
Arrêt suite au bas niveau d'huile	13	ENTRETIEN DE L'APPAREIL	16
Silencieux Pare-étincelles	13	Raccords	16
SPÉCIFICATIONS	13	Ajutage	16
CHOIX DE BUSE DE PULVÉRISATION	13	Filtre à eau	16
AVANT TOUTE UTILISATION	14	Entretien du moteur	16
Préparation précédant la mise en marche	14	RANGEMENT	17
Montage du tuyau et du pistolet	14	Rangement de la pompe	17
Lubrification du moteur	14	Rangement du moteur	17
Carburant	14	GARANTIE LIMITÉE	17
CARACTERISTIQUES DE MOTEUR ET POMPE	14	DÉPANNAGE	18
RACCORDEMENTS	15	LISTE DES PIÈCES ET SCHEMA DES PIÈCES	28-31
Tuyau haute pression	15		
Raccordement d'eau	15		

INDICE

INTRODUCTION	19	INSTRUCCIONES DE OPERACIÓN	23
SERVICIO PARA LOS CLIENTES	19	Procedimiento de arranque	23
SEGURIDAD	19	Encendido del motor	23
Símbolos de seguridad	19	INYECCIÓN DE QUÍMICOS	23
Precauciones generales de seguridad	20	TÉCNICAS DE LIMPIEZA	24
CARACTERÍSTICAS DE SEGURIDAD	21	Aplicación de jabón y desgrasador	24
Válvula de descarga de calor	21	Aplicación de cera	24
Dispositivo de seguridad	21	FIN DE LA OPERACIÓN DE LIMPIEZA	24
Apagado por bajo nivel de aceite	21	MANTENIMIENTO	24
Silenciador apagachispas	21	Conexiones	24
ESPECIFICACIONES	21	Boquilla	24
SELECCIÓN DE BOQUILLA DE PULVERIZACIÓN	21	Rejilla de agua	24
ANTES DE LA OPERACIÓN	22	Mantenimiento del motor	24
Preparación inicial	22	ALMACENAMIENTO	25
Ensamblado de manguera y pistola	22	Almacenamiento de la bomba	25
Lubrificación del motor	22	Almacenamiento del motor	25
Combustible	22	GARANTIA LIMITADA	25
CARACTERÍSTICAS DE MOTOR Y BOMBA	22	RESOLUCION DE PROBLEMAS	26
CONEXIONES DE OPERACIÓN	23	LISTA DE PIEZAS Y DIAGRAMA DE PIEZAS	28-31
Manguera de alta presión	23		
Conexión de agua	23		

Congratulations on purchasing a Pro Force® Pressure Washer. Whether you are doing light cleaning at home or are needing power to do the tough jobs, Pro Force® pressure washers are built to give you the power you need. By following proper break-in procedures, using recommended set-up and operating procedures, and performing preventive maintenance as specified in this manual, your Pro Force® pressure washer will serve you for years to come.

Most important is the safety of you and those around you. Remember that while the Pro Force® pressure washer gives you the power you need to complete your job, safety rules should always be followed.

Thank you for selecting our product.

MAT Industries, LLC

CUSTOMER SERVICE

Call our toll free number
1-888-895-4549
8 a.m. to 5 p.m. C.S.T.
or www.pro-forceproducts.com
to obtain warranty service information or
order replacement parts or accessories.

Please have the following information available:

1. Model Number.
2. Serial Number.
3. Date and where purchased.
4. Replacement numbers if you are ordering parts.

MAT Industries, LLC
6700 Wildlife Way
Long Grove, IL 60047
Attention: Warranty Service Department

www.pro-forceproducts.com

Safety Symbols

The following symbols are used throughout this manual. Follow listed instructions to ensure your safety.

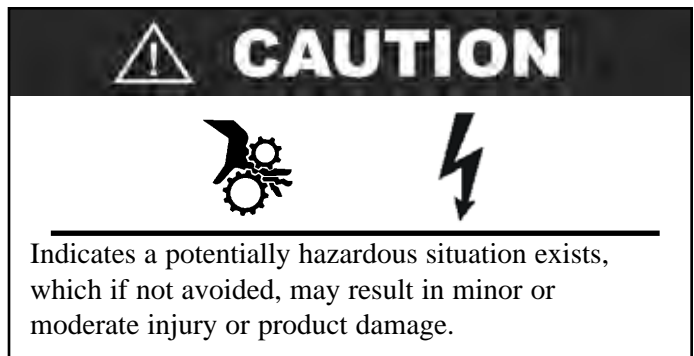
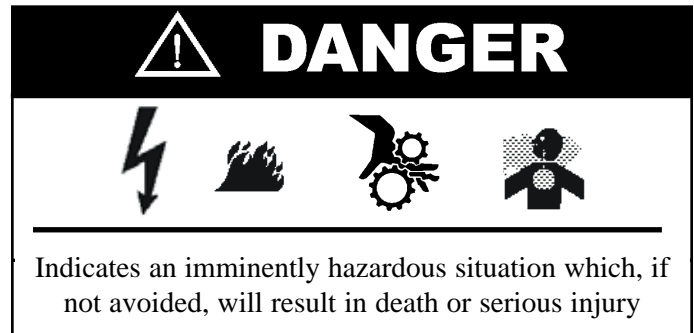



NOTE: Indicates operation or maintenance information helpful to improve performance or operation.



CALIFORNIA PROPOSITION 65 WARNING
This product contains chemicals known to the State of California to cause cancer, birth defects and/or reproductive harm.

The following Safety Precautions apply whenever using, storing or servicing Pro Force® Pressure Washers or their engines to reduce the possibility of personal injury. Overlooking or ignoring these precautions can lead to personal injury or product damage.

 **WARNING**



- Read this manual carefully. Know your equipment. Consider applications, potential hazards and limitations for your unit.
- Know your equipment. Consider the applications, limitations, and the potential hazards specific to your unit.
- Store the pressure washer in a well ventilated area with the fuel tank empty. Fuel should not be stored near the pressure washer.
- Never operate under these conditions:
 - a. A noticeable change in engine speed.
 - b. A noticeable loss of pressure.
 - c. The engine misfires.
 - d. Smoke or flames are present.
 - e. Enclosed compartment.
 - f. Excessive vibration.
 - g. Rain or inclement weather.
- Water spray must never be directed towards any electric wiring or directly towards the pressure washer.
- Do not allow the hose to come in contact with hot muffler.
- Equipment must be placed on a firm, supporting surface.
- Remove the spark plug or cable from the spark plug to prevent accidental starting when not in use or prior to detaching the high pressure hose.
- Keep the pressure washer clean and free of oil, mud and other foreign matter.
- Do not wear loose clothing, jewelry, or anything that may be caught in the engine.
- Never direct spray at people or pets.
- Never allow children to operate pressure washer at any time.
- Use both hands to control the wand.

 **WARNING**



- Do not touch nozzle or water spray while operating.
- Wear safety goggles while operating.
- Only approved hoses and nozzles should be used.
- The trigger gun must not be jammed in “ON” position during operation.
- Never tie knots or kink the high pressure hose.
- All hose connections must be properly sealed.
- Prior to starting the pressure washer in cold weather, be sure ice has not formed in any part of the equipment.
- Use only recommended chemicals.
- Outdoors use only.
- Place the pressure washer away from cleaning site during operation.
- To prevent accidental discharge, the spray gun should be secured by locking trigger when not in use.
- Do not run the pressure washer for more than five minutes without depressing the trigger or damage to the pump may result.
- Check the fuel system periodically for leaks or signs of deterioration such as chafed or spongy hose, loose or missing clamps, or damaged tank or cap. All defects should be corrected before operation.
- Do not touch hot muffler.
- Service, operate and refuel under the following conditions.
 - a. Good ventilation.
 - b. Refuel the pressure washer in a well lighted area.
 - c. Avoid fuel spills and never refuel while the pressure washer is running.
 - d. Avoid an ignition source when refueling.
 - e. Use lead free fuel with a minimum of 85 octane.
- Do not smoke near the pressure washer.
- Do not use damaged high-pressure hoses.

SAFETY FEATURES

THERMAL RELIEF VALVE

A thermal relief valve is provided to protect the pump from overheating if the spray gun is closed for an extended length of time or the nozzle becomes plugged. However, it is intended to be used as a backup system and every effort should be made to not permit the pump to heat up.

We recommend turning the pressure washer off if it will not be used for more than five minutes. This saves wear on the unit, reduces fuel consumption and extends the life of the pump by avoiding heat.

SAFETY LOCK OFF LATCH

To prevent accidental discharge of high pressure water, the safety latch on the trigger should be engaged whenever the pressure washer is not in use. (Refer to Operating Instructions.)

LOW-OIL SHUTDOWN

The unit is equipped with a low oil sensor. If the engine oil level becomes lower than required, the pressure washer will automatically shut off. (Refer to the engine manual for this feature.) This protects your pressure washer engine from operating without proper lubrication.

If the pressure washer engine shuts off and the oil level is according to specification, check to see if the pressure washer is sitting at an angle that forces oil to shift. Place on an even surface to correct this. If the engine fails to start, the oil level may not be sufficient to deactivate low oil level switch. Be sure the engine is completely full of oil. See engine manual.



The pump will overheat and may be damaged, or cause damage if allowed to circulate more that five minutes.

SPARK ARRESTING MUFFLER

THIS PRODUCT MAY NOT BE EQUIPPED WITH A SPARK ARRESTING MUFFLER. If the product will be used around flammable materials, such as agricultural crops, forests, brush, grass, or other similar items, then an approved spark arrester should be installed and is legally required in the State of California. The California statutes requiring a spark arrester are Sections 13005(b), 4442 and 4443. Spark Arresters are also required on some U.S. Forest Service land and may also be legally required under other statutes and ordinances. For more information, contact our Customer Service Department at 1-888-895-4549 or www.pro-forceproducts.com.

SPECIFICATIONS

Maximum Inlet Pressure Up to 90 PSIG
RPM 3600 RPM
Temperature of Pumped Fluids Up to 80°F
Inlet Ports 3/4" GHT (F)
Discharge Ports M22

Your pressure washer has a maintenance-free pump. There is no need to change the pump oil.

Consult the factory for special requirements that must be met if the pump is to operate beyond one or more of the limits specified above.

SPRAY NOZZLE SELECTION

Following is information concerning the three nozzles provided with your pressure washer.

NOTE: The force of the spray on the surface you are cleaning increases as you move closer to the surface.

0° High Pressure (Red): The water stream discharged is very aggressive. Use with extreme caution to prevent damage to the surface being cleaned or injury to persons or animals.

15° High Pressure (Yellow): This is the nozzle used for most cleaning applications. It provides narrow coverage and a highly powerful water stream.

25° High Pressure (Green): Use of this nozzle offers both a medium coverage and water stream. Best used for flushing dirt and debris off surfaces.

40° High Pressure (White): This nozzle is used for cleaning with the widest coverage over a larger area with a powerful water stream.

65° Low Pressure (Black): Provides low pressure spray and a wide coverage. Used primarily when operating the chemical injector to apply chemicals.

BEFORE OPERATION

NOTE: The engine and pump on your Pro Force® Pressure Washer will often have improved performance after a break-in period of several hours.

PRE-START PREPARATION

Before starting the pressure washer, check for loose or missing parts and for any damage which may have occurred during shipment.

HOSE AND GUN ASSEMBLY

NOTE: Align threaded connections carefully to prevent damaging threads during assembly. Tighten connections securely to prevent leaks during operation.

Attach the hose to the inlet of the trigger gun.

LUBRICATION

DO NOT attempt to start the pressure washer engine without filling the engine crank case with the proper amount and type of oil. (See the accompanying engine manual for this information.) Your pressure washer engine has been shipped from the factory without oil in the engine crankcase. Operating the unit without oil will ruin the engine.

The pump is not equipped with a dipstick or side glass window. Check oil leaks from the pump. Pump oil is shipped in the pump from factory.

FUEL

Fill the tank with clean, fresh unleaded automotive gasoline. (See Figure 1). Regular grade gasoline may be used provided a high octane rating is obtained (at least 85 pump octane).

⚠ **WARNING**

Gasoline is very dangerous. Serious injury may result from fire caused by gasoline contacting hot surfaces.

Do not overfill the tank. Keep maximum fuel level 1/2 inch below the bottom of the filler neck. This will allow expansion in hot weather and prevent overflow.

ENGINE AND PUMP FEATURES - FIGURE 1

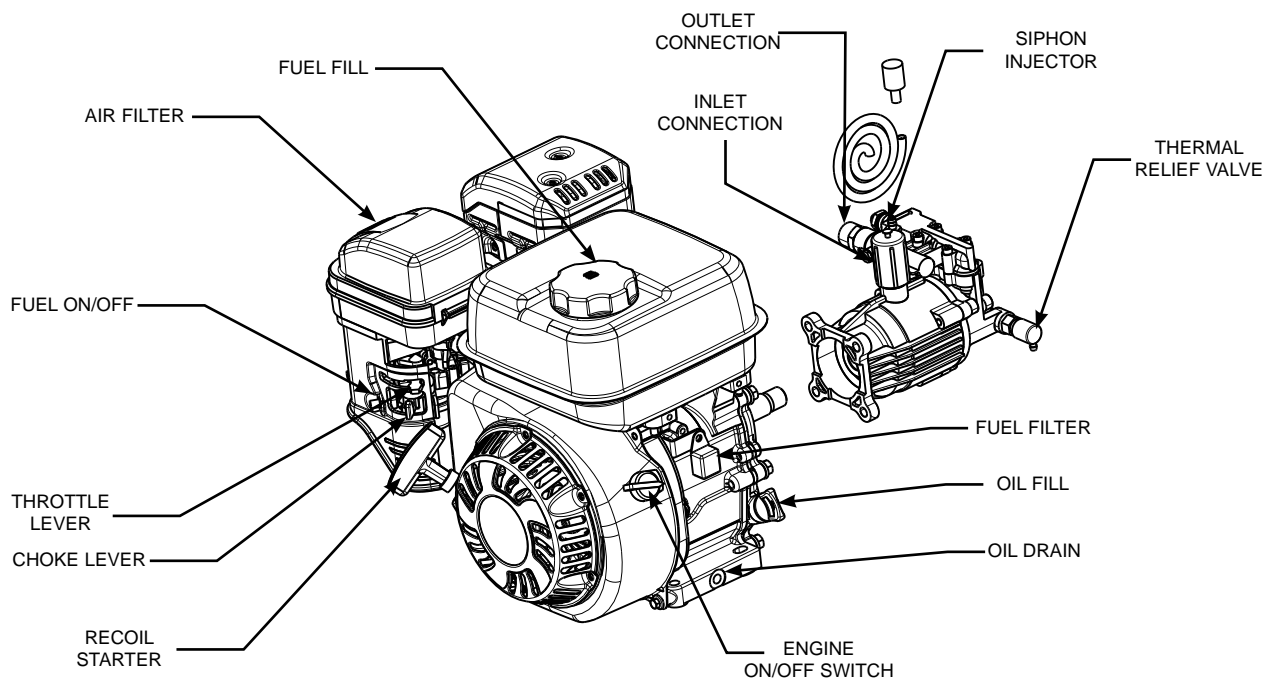

OPERATING CONNECTIONS

HIGH PRESSURE HOSE

Attach the high pressure hose to the outlet connection located on the pump. (See Figure 1, page 6).

NOTE: DO NOT use a high pressure hose from another manufacturer.

WATER CONNECTION

Before connecting to unit, run water through the garden hose (not supplied) to flush out any foreign matter. Check that the screen is clean and is in the inlet of the pump. Attach garden hose to the inlet connection located on the pump. (See Figure 1, page 6).

NOTE: The water supply must provide a minimum of 4 g.p.m. at 40 to 80 p.s.i. or the pump will be damaged.

OPERATING INSTRUCTIONS

START-UP PROCEDURE

1. Ensure water supply is connected and turned on.
2. Release gun safety lock.
3. To allow air to escape from the hose, squeeze trigger on the gun until there is a steady stream of water coming from the nozzle.
4. Remove any dirt or foreign matter from the gun outlet and the male connector of the wand.
5. Insert the nozzle wand into the gun wand and tighten the twistfast fitting securely by hand.

WARNING



If the wand or nozzle is not securely locked into place, it could be ejected under high pressure when operating the gun, possibly causing injury or damage.

STARTING THE ENGINE (See Figure 1, page 6)

1. Check oil and fuel level.
2. Adjust choke as necessary.
3. Set the engine switch to the "ON" position.
4. Squeeze trigger on pressure washer to release pressure while pulling on the engine starter rope with a fast steady pull. Pressure may otherwise build up making starting the unit difficult.
5. As the engine warms up, open the choke to full.

CHEMICAL INJECTION



CAUTION

This pressure washer is intended for use only with liquid car wash detergents, developed specifically for pressure washer and with mild soaps. Only use chemicals compatible with the aluminum and brass parts of the pressure washer. Powdered soaps may clog the injection system. Always use chemicals according to manufacturer directions. MAT Industries, LLC assumes no responsibility for any damages caused by chemicals injected through this pressure washer.

1. Ensure that one end of the chemical injection tube is attached to the siphon injector on the pump (see figure 1)
2. Ensure that the other end of the chemical injection tube is attached to the nipple on the bottom of the chemical tank (see figure 2)
3. Fill your chemical tank with your cleaner of choice (most cleaners are concentrated, please follow the mixing instructions as outlined by the manufacturer of the cleaner).
4. Install the black quick connect, low pressure nozzle on the spray wand. The solution will automatically be mixed with the water and discharged through the nozzle.

CLEANING TECHNIQUES

Cleaning Techniques

When cleaning with the pressure washer, many cleaning tasks can be solved with water alone, but for most tasks it is advantageous to use a detergent also. A detergent ensures a quick soaking of the dirt allowing the high pressure water to penetrate and remove the dirt more effectively.

Pressure washer chemicals are specially formulated to be used with your pressure washer.

APPLICATION OF SOAP OR DEGREASER

1. Apply the solution to a DRY work surface.
On a vertical surface, apply horizontally from side to side starting from the bottom to avoid streaking.
NOTE: Wetting the surface first is not recommended, as it dilutes the detergent and reduces its cleaning ability. Avoid working on hot surfaces or in direct sunlight to minimize the chances of the chemical damaging painted surfaces. Damage may occur to painted surface if chemical is allowed to dry on the surface. Hold nozzle far enough away from surface to prevent damage to the surface.
2. Allow chemical to remain on the surface for a short time before rinsing.
3. Rinse with clean water under high pressure. On a vertical surface, first rinse from the bottom up, then rinse from the top down. Hold nozzle 6 to 8 inches from the work surface at a 45° angle using the flat spray as a peeling tool rather than a scrub brush.

APPLICATION OF WAX

1. Immediately after cleaning, apply pressure washer wax. Place injection tube in container of wax.
2. Apply the wax sparingly in an even layer. Apply to wet surfaces from the bottom up for even distribution and to avoid streaking.
3. Remove the suction tube from the wax bottle and rinse off the surplus wax.

NOTE: IF SURPLUS WAX IS NOT REMOVED, A HAZY FINISH MAY RESULT.

4. Wipe dry to reduce water spotting.

END OF CLEANING OPERATION

End of Cleaning Operation

When you have completed use of the chemical injection system, remove tube from container. Continue to run in low pressure position and inject clean water through the tube and injection system by placing end of tube in a container of clean water. Continue to run until it is thoroughly cleaned.

MAINTENANCE

CONNECTIONS

Connections on pressure washer hoses, gun and spray wand should be cleaned regularly and lubricated with silicon grease to prevent leakage and damage to the o-rings.

NOZZLE

Clogging of the nozzle causes the pump pressure to be too high and cleaning is immediately required.

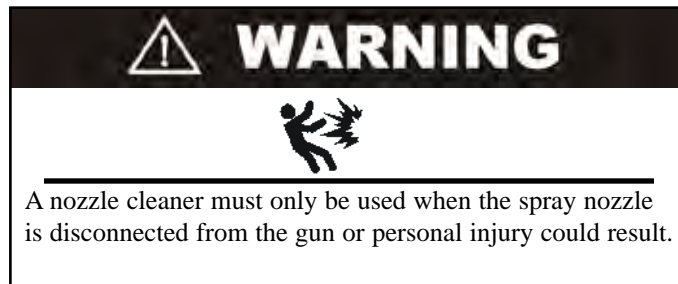

1. Remove the nozzle from the wand.
2. Clear the nozzle with the nozzle cleaner pin provided with the pressure washer.
3. Flush the nozzle backwards with water.
4. Re-install the nozzle into the wand.

Restart the pressure washer and depress the trigger on the spray gun. If the nozzle is still plugged or partially plugged, repeat above items 1-4.

If the previous procedure does not clear the nozzle, replace with a new nozzle.

WATER SCREEN

The pressure washer is equipped with a water inlet screen to protect the pump. If the screen is not kept clean, it will restrict the flow of water to the pressure washer and may cause damage to the pump. Do not damage the screen while removing or cleaning screen. Any foreign particles entering the pump may damage the pump. Do not operate pressure washer without the screen in place.

Remove the screen and back flush to remove impurities from screen. Replace immediately.

ENGINE MAINTENANCE

During the winter months, rare atmospheric conditions may develop which will cause an icing condition in the carburetor. If this develops, the engine may run rough, lose power, and may stall.

NOTE: Refer to the engine manufacturer's manual for service and maintenance of the engine.

STORAGE

PUMP STORAGE

If you must store your pressure washer in a location where the temperature is below 32°F, you can minimize the chance of damage to your machine by utilizing the following procedure:

1. Shut off water supply and relieve pressure in the spray gun by depressing the trigger. Disconnect the garden hose from the pressure washer, but leave the high-pressure hose connected.
2. Tip the unit on its side with the inlet connection pointing up.
3. Insert a small funnel (to prevent spilling) into the inlet and pour in approximately 1/4 cup of RV antifreeze.
4. Disconnect spark plug wire.
5. Without connecting garden hose pull the recoil several times to circulate the antifreeze in the pump system. Continue to add antifreeze and pull the recoil until the antifreeze is expelled when the trigger is pulled.
6. Turn the unit upright.



CAUTION

Prior to restarting, thaw out any possible ice from the pressure washer hoses, spray gun and wand.

Another method of reducing risks of freeze damage is to drain your pressure washer as follow:

1. Stop the pressure washer and detach supply hose and high pressure hose. Squeeze the trigger of the discharge gun to drain all water from the wand and hose.
2. Restart the pressure washer and let it run briefly (about 5 seconds) until water no longer discharges from the high pressure outlet.

ENGINE STORAGE

When the pressure washer is not being operated or is being stored more than one month, follow these instructions:

1. Replenish engine oil to upper level.
2. Drain gasoline from fuel tank, fuel line, fuel valve and carburetor.
3. Pour about one teaspoon of engine oil through the spark plug hole, pull the recoil starter several times and replace the plug. Then pull the starter slowly until you feel increased pressure which indicates the piston is on its compression stroke and leave it in that position. This closes both the intake and exhaust valves to prevent the inside of the cylinder from rusting.
4. Cover the pressure washer and store in a clean, dry place that is well ventilated away from open flame or sparks.

NOTE: We recommend always using a fuel stabilizer. A fuel stabilizer will minimize the formulation of fuel gum deposits during storage. The fuel stabilizer can be added to the gasoline in the fuel tank, or into the gasoline in a storage container.

LIMITED WARRANTY

Warranty Coverage: MAT Industries, LLC (the Company) warrants to the original retail customer in North America that it will repair or replace, free of charge, any parts found by the Company or its authorized service representative to be defective in material or workmanship. This warranty covers the cost of replacement parts and labor for defects in material or workmanship.

Not Covered:

- Transportation charges for sending the product to the Company or its authorized service representative for warranty service, or for shipping repaired or replacement products back to the customer; these charges must be borne by the customer.
- Engine may be covered exclusively by a separate warranty from the engine manufacturer as set forth in the engine Manual (if included).
- Damages caused by abuse or accident, and the effects of corrosion, erosion and normal wear and tear.
- Warranty is void if the customer fails to maintain and operate the product as instructed and recommended by the Company in the owner's manual.
- Warranty applies only if the product is used solely for consumer applications, and does not apply if the product is used for commercial or business applications, or as rental equipment.
- The Company will not pay for repairs or adjustments to the product, or for any costs or labor, performed without the Company's prior authorization.

Warranty Period: One (1) year from the date of purchase. For warranty service, the customer must provide dated proof of purchase and must notify the Company within the warranty period.

For warranty service: Call toll free 1-888-895-4549, or write to MAT Industries, LLC, 6700 Wildlife Way, Long Grove, IL 60047.

EXCLUSIONS AND LIMITATIONS: THE COMPANY MAKES NO OTHER WARRANTY OF ANY KIND, EXPRESS OR IMPLIED. IMPLIED WARRANTIES, INCLUDING WARRANTIES OF MERCHANTABILITY AND OF FITNESS FOR A PARTICULAR PURPOSE, ARE HEREBY DISCLAIMED. THE WARRANTY SERVICE DESCRIBED ABOVE IS THE EXCLUSIVE REMEDY UNDER THIS WARRANTY; LIABILITY FOR INCIDENTAL AND CONSEQUENTIAL DAMAGES IS EXCLUDED TO THE EXTENT PERMITTED BY LAW.

This warranty gives you specific legal rights, and you may also have other rights which vary from state to state. Some states do not allow a disclaimer of implied warranties, or the exclusion or limitation of incidental and consequential damages, so the above disclaimers and exclusions may not apply to you.

PROBLEM	POSSIBLE CAUSE	CORRECTION	
Engine will not start or stops while operating.	Low-oil shutdown.	Fill engine with oil.	
	Engine switch not in the "ON" position.	Turn switch "ON".	
	Pressure build up in hose.	Squeeze trigger.	
Engine is overloaded.	Nozzle partially blocked.	Clean nozzle.	
	Excessive pressure.	Reduce pressure by using pressure adjustment knob	
Water or oil leaking from bottom of pump.	A small amount of leakage is normal.	If excessive leaking occurs call the Customer Service Department.	
Pressure increases when gun is closed.	Bypass valve not operating properly.	Call the Customer Service Department.	
Engine running but pump not building maximum pressure or has irregular pressure.	Faucet closed	Open faucet.	
	Unit has been stored in freezing temperatures.	Thaw out unit completely including hose, gun and wand.	
	Inadequate water supply.	Provide a minimum of 4 gpm at 20 psi.	
	Water inlet screen clogged.	Clean screen.	
	Kink in garden hose.	Straighten hose	
	Wand nozzle worn or damaged.	Replace nozzle,	
	Air in pump.	Let run with gun open and wand removed until steady stream of water is released.	
	Suction or discharge valves clogged or worn out.	Call the Customer Service Department.	
No intake of chemicals	By-pass valve not operating effectively.	Call the Customer Service Department.	
	Injection tube not securely inserted into unit.	Push firmly into injector.	
	Tube cracked or split.	Replace tubing.	
	Wrong nozzle.	Switch to low pressure nozzle.	
	Injection tube strainer clogged.	Clean strainer.	
Trigger will not move.	Nozzle blocked.	Clean nozzle.	
	Dried chemicals in injector.	Dissolve by running warm water trough the injection tube.	
	Gun safety lock engaged.	Release safety lock.	
	Water in crankcase.	High humidity.	Change oil more frequently.
		Worn seals.	Call the Customer Service Department.
Noisy operation.	Worn bearings	Call the Customer Service Department.	
	Air mixed with water.	Check inlet lines for restrictions and /or proper sizing.	
Rough/pulsating operation with pressure drop.	Worn packing.	Call the Customer Service Department.	
	Inlet restriction.	Check system for stoppage, air leaks, correctly sized inlet plumbing to pump.	
	Unloader.	Check unloader for proper operation.	
	Air mixed in water.	Check inlet lines for restrictions and/or proper sizing.	
High crankcase temperatures.	Wrong grade of oil.	Use recommended oil.	
	Improper amount of oil in crankcase.	Adjust oil level to proper amount.	

PARTS DRAWING / SCHEMA DES PIÈCES / DIAGRAMA DE PIEZAS

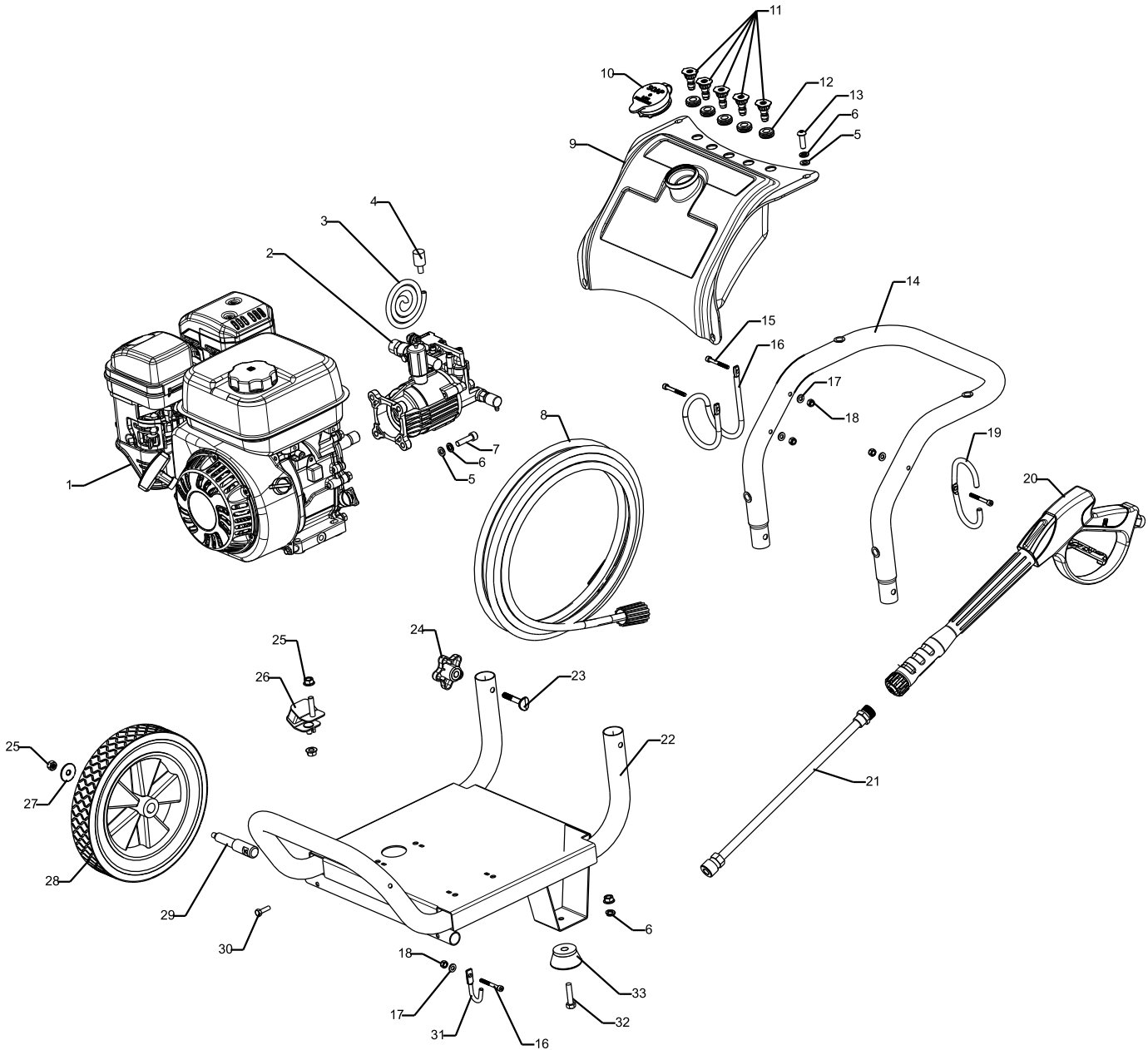

PARTS LIST / LISTE DES PIÈCES / LISTA DE PIEZAS

REF NO.	PART NO.	DESCRIPTION	DESCRIPTION	DESCRIPCION	QTY
1	Note A Remarque A Nota A	Assembly, Engine 212cc Rato, R210	Assemblage, Moteur 212cc Rato, R210	Ensamble, Motor 212cc Rato, R210	1
2	E104755	Assembly, Pump Honbase, Brass Head AXB28	Assemblage, Pompe Honbase, Tête en cuivre AXB28	Ensamble, Bomba Honbase, Cabeza de Latón AXB28	1
3	E104141	Hose, Chemical	Tuyau, produit chimique	Manguera, Químico	1
4	E104142	Filter, Chemical	Filtre, produit chimique	Filtro, Químico	1
5	Note B Remarque B Nota B	Washer, Flat M8 X 15mm OD	Rondelle, plate M8 X 15mm dia. ext.	Arandela, Plana M8 X 15mm DE	8
6	Note B Remarque B Nota B	Washer, Lock M8	Rondelle de blocage M8	Arandela, Seguridad M8	8
7	Note B Remarque B Nota B	Screw, SHC M8 X 1.25 X 20MM	Vis hexagonale à tête creuse M8 X 1,25 X 20MM	Tornillo, cabeza Allen M8 X 1.25 X 20MM	4

PARTS LIST / LISTE DES PIÈCES / LISTA DE PIEZAS

REF NO.	PART NO.	DESCRIPTION	DESCRIPTION	DESCRIPCION	QTY
8	E104816	Hose, Assembly, 1/4", 25ft, 20Mpa Rating	Tuyau, Assemblage, 1/4", 25ft, 20Mpa nominal	Manguera, Ensamble, 1/4", 25ft, Clasificación 20Mpa	1
9	E104839	Tank, Chemical	Réservoir, produit chimique	Tanque, Químico	1
10	E104575	Cap, Chemical Tank	Bouchon, réservoir de produit chimique	Tapa, Tanque de Químicos	1
11	E104817	Nozzles, 3.5 QC, 5 Pack with soap nozzle	Buses, 3,5 QC, emballage de 5 avec buse à savon	Boquillas, 3.5 QC, Paquete de 5 con boquilla de jabón	1
12	E104126	Grommet, Nozzle	Oeillet, buse	Ojal, Boquilla	5
13	Note B Remarque B Nota B	Screw, M8 X 1.25 X 25mm SBHCS	Vis, à tête ronde creuse M8 X 1,25 X 25mm	Tornillo, cabeza Allen redonda M8 X 1.25 X 25mm	4
14	E104055	Tube, Upper Arms	Tube, bras supérieurs	Tubo, Brazos Superiores	1
15	Note B Remarque B Nota B	Screw, SHCS, M6 X 1.0 X 45mm	Vis hexagonale à tête creuse M6 X 1,0 X 45mm	Tornillo, cabeza Allen plana M6 X 1.0 X 45mm	4
16	E104043	Hook, Hose (PM Red)	Crochet, tuyau (rouge PM)	Gancho, Manguera (Rojo PM)	1
17	Note B Remarque B Nota B	Washer, Lock M6	Rondelle de blocage M6	Arandela, Seguridad M6	4
18	Note B Remarque B Nota B	Nut, M6 X 1.0 Nyloc	Écrou, nyloc M6 X 1,0	Tuerca, Nyloc M6 X 1.0	4
19	E104042	Hook, Wand (PM Red)	Crochet, tube rallonge (rouge PM)	Gancho, Varilla (Rojo PM)	1
20	E104822	Gun, Pressure Washer, Ergonomic w Color Touch Points	Pistolet, nettoyeur à pression, ergonomique avec points de touche colorés	Pistola, Lavadora a Presión, Ergonomica con Puntos de Contacto a Color	1
21	E104102	Assy, wand & quick connect, 15.125 inch	Assemblage, tube rallonge et connexion rapide, 15,125 po	Ensamble, varilla y conexión rápida, 15.125 pulgadas	1
22	E104053	Weldment, Base	Ensemble soudé, base	Soldadura, Base	1
23	E104063	Bolt, Saddle M8x45	Boulon, selle M8x45	Perno, Asiento M8x45	2
24	E104064	Knob, Five Prong	Bouton, cinq pattes	Perilla, Cinco Puntas	2
25	Note B Remarque B Nota B	Nut, M8x1.25 Nyloc	Écrou, nyloc M8x1,25	Tuerca, Nyloc M8x1.25	12
26	E104099	Isolator, Engine	Isolateur, moteur	Aislador, Motor	4
27	Note B Remarque B Nota B	Washer, Flat M8x28mm-mODx2mm Thk Finish (bright Zinc)	Rondelle plate M8x28mm dia ext x 2mm épais fini (zinc brillant)	Arandela, Plana M8x28mmDEx2mm Acabado grueso (zinc brillante)	2
28	E104807	Wheel, 10" Dia X 1.75" Wide, Solid Rubber	Roue, 10" Dia X 1,75" large, caoutchouc plein	Rueda, 10" Diámetro X 1.75" Ancho, Goma Sólida	2
29	E104045	Spud, Wheel (Short)	Support, roue (court)	Eje, Rueda (Corto)	2
30	Note B Remarque B Nota B	Screw, HFH M6 X 1.0 X 20MM (Yellow Zinc Dich Plate)	Vis, HFH M6 X 1,0 X 20MM (zinc jaune plaqué Dich)	Tornillo, cabeza hexagonal M6 X 1.0 X 20MM (Placa de Zinc Amarilla)	2
31	E104044	Hook, Wand Tip (PM Red)	Crochet, bout du tube rallonge (rouge PM)	Gancho, Punta de la Varilla (Rojo PM)	1
32	Note B Remarque B Nota B	Screw, HH M8 x 1.25 x 30 MM	Vis à tête hexagonale M8 x 1,25 x 30 MM	Tornillo, cabeza hexagonal M8 x 1.25 x 30 MM	2
33	E104808	Isolators, Pressure Washer Frame	Isolateurs, cadre du nettoyeur à pression	Aisladores, Marco de la Lavadora a Presión	2

Note A: Consult the accompanying engine manual or contact our service department for assistance.

Note B: These are standard parts available at your local hardware store.

Remarque A: Consulter le manuel du moteur inclus ou contacter notre service après-vente pour toute assistance.

Remarque B: Ces pièces sont des pièces standard disponibles dans les quincailleries.

Nota A: Consulte el manual adjunto del motor o comuníquese con nuestro departamento de servicio para recibir asistencia al respecto.

Nota B: Estas son piezas estándar disponibles en su ferretería local.

PUMP / POMPE / BOMBA

PARTS DRAWING / SCHEMA DES PIÈCES / DIAGRAMA DE PIEZAS

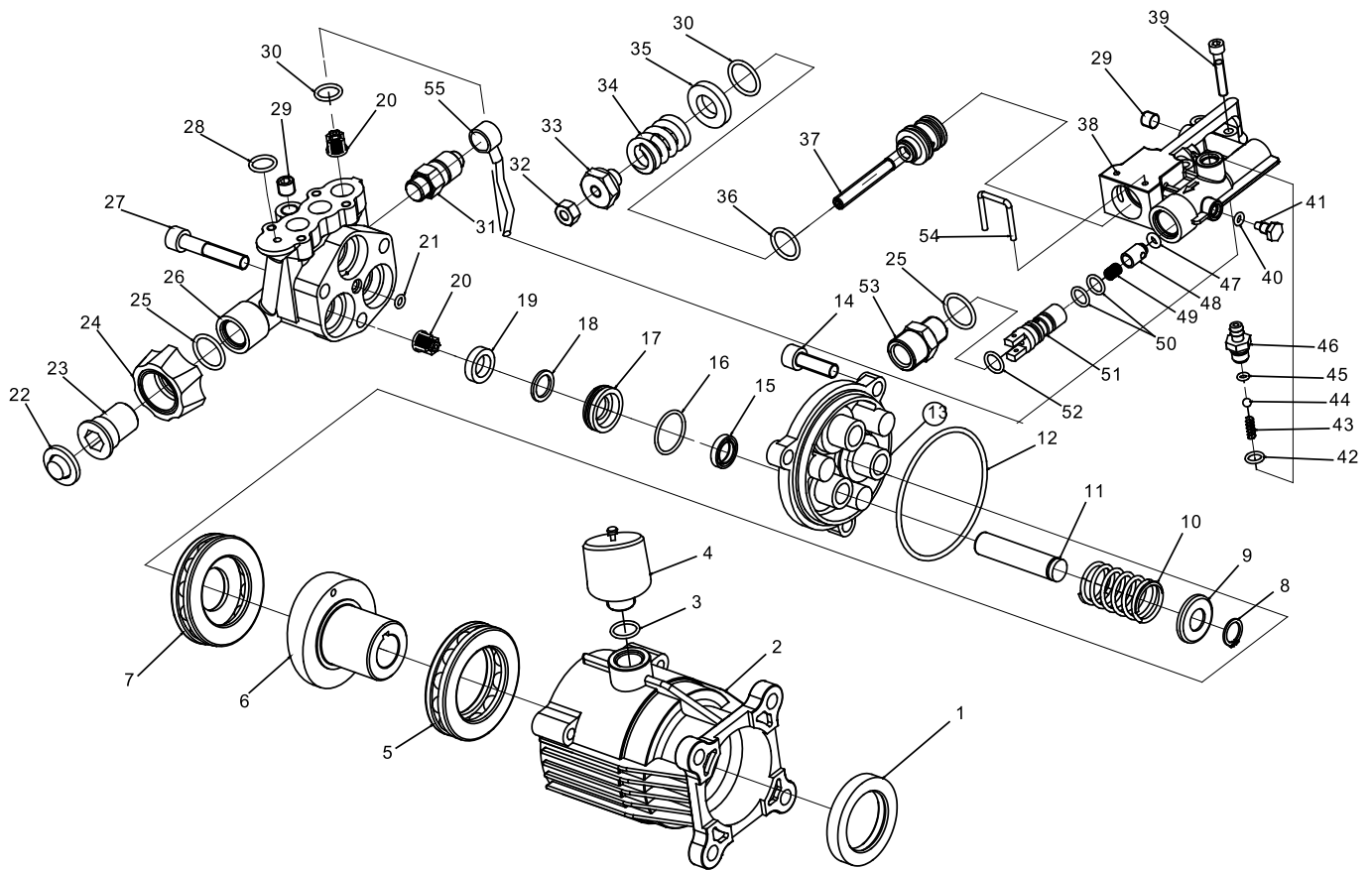

Repair Kits

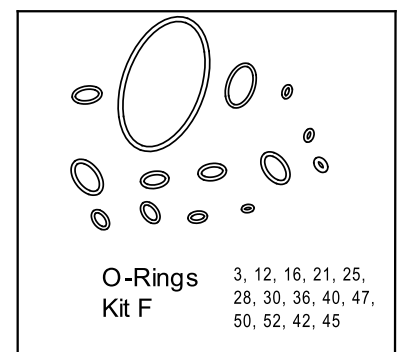
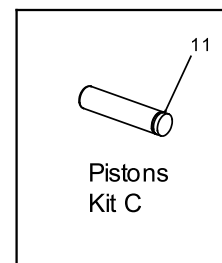
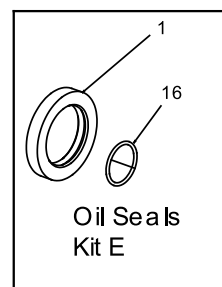
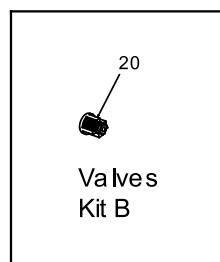
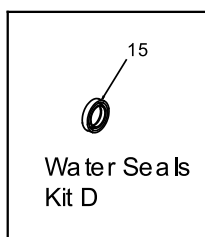
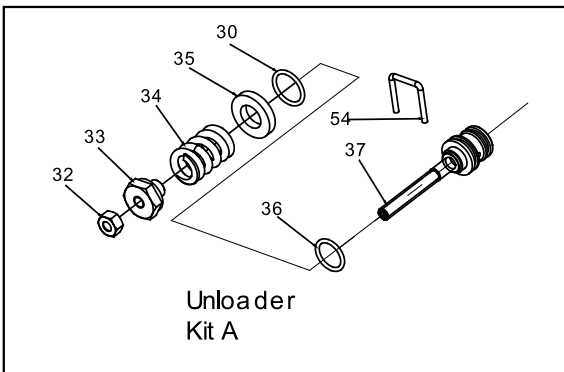

PUMP / POMPE / BOMBA
PARTS LIST / LISTE DES PIÈCES / LISTA DE PIEZAS

REF	PART NO.	DESCRIPTION	DESCRIPTION	DESCRIPCION	QTY
	E104755	Pump	Pompe	Bomba	
A		Unloader Kit	Jeu de Régulateur de pression	Juego de Descargador	
B		Valves Kit	Jeu de Soupapes	Juego de Válvulas	
C		Pistons Kit	Jeu de Pistons	Juego de Pistóns	
D		Water Seals Kit	Jeu de Joints l'eau	Juego de Sello del agua	
E		Oil Seals Kit	Jeu de Joints l'eau	Juego de Sello del agua	
F		O-Rings Kit	Jeu de Joints torique	Juego de Anillo tórico	
1		Seal	Joint	Sello	1
2		Housing	Corps	Compartimiento	1
3		O-Ring (18x2.4)	Joint torique	Anillo tórico	1
4		Breather	Reniflard	Respiro	1
5		Bearing	Roulement	Cojinete	1
6		Hollow shaft	Arbre	Túnel	1
7		Bearing	Roulement	Cojinete	1
8		Circlip	Anneau de retenue	Anillo retenedor	3
9		Ring	Segment	Anillo	3
10		Spring	Ressort	Resorte	3
11		Piston	Piston	Pistón	3
12		O-Ring (73 x 2.65)	Joint torique	Anillo tórico	1
13		Housing	Corps	Compartimiento	1
14		Bolt M8 x 25 8.8	Boulon M8 x 25 8.8	Perno M8 x 25 8.8	3
15		Seal	Joint	Sello	3
16		O-Ring (22.4 x 1.8)	Joint torique	Anillo tórico	3
17		Bushing	Bague	Buje	3
18		Bushing	Bague	Buje	3
19		Seal (13 x 20 x 5)	Joint	Sello	3
20		Valve	Soupape	Válvula	6
21		O-Ring (4.5 x 1.8)	Joint torique	Anillo tórico	1
22		Filter	Filtre	Filtro	1
23		Suction fitting	Raccord de succion	Adaptador de succión	1
24		Suction fitting 3/4"	Raccord de succion	Adaptador de succión	1
25		O-Ring (14 x 1.8)	Joint torique	Anillo tórico	2
26		Pump head	Tête de pompe	Cabeza de bomba	1
27		Head bolt M8 x 45 10.9	Boulon M8 x 45 10.9	Perno M8 x 45 10.9	3
28		O-Ring (12 x 2)	Joint torique	Anillo tórico	1
29		Plug	Bouchon	Tapón	2
30		O-Ring (14 x 2)	Joint torique	Anillo tórico	4
31		Thermal relief valve	Thermal vestige tuyau	Térmico reliquia válvula	1
32		Nut M6	Écrou	Tuerca	1
33		Nut	Écrou	Tuerca	1
34		Spring	Ressort	Resorte	1
35		Plate spring	Plaque	Placa	1
36		O-Ring (12.42 x 1.78)	Joint torique	Anillo tórico	1
37		Unloader	Régulateur de pression	Descargador	1
38		Housing	Corps	Compartimiento	1
39		Bolt M5 x 30 10.9	Boulon M5 x 30 12.9	Perno M5 x 30 12.9	5
40		O-Ring (4 x 2)	Joint torique	Anillo tórico	1
41		Plug	Bouchon	Tapón	1
42		O-Ring (7.65 x 1.78)	Joint torique	Anillo tórico	1
43		Spring	Ressort	Resorte	1
44		Ball	Balle	Pelota	1
45		O-Ring (3.68 x 1.78)	Joint torique	Anillo tórico	1
46		Hose nipple	Manchon fileté	Niple	1
47		O-Ring (4 x 2.65)	Joint torique	Anillo tórico	1
48		Jet	Jet	Jet	1
49		Spring	Ressort	Resorte	1
50		O-Ring (9 x 1.8)	Joint torique	Anillo tórico	1
51		Detergent injector	Injecteur	Inyector	1
52		O-Ring (10 x 1.8)	Joint torique	Anillo tórico	1
53		Outlet fitting	Raccord de sortie	Adaptador de salida	1
54		Clip	Clip	Clip	1
55		Hose	Tuyau	Manguera	1

MAT Industries LLC

**6700 Wildlife Way
Long Grove, IL 60047**

1-888-895-4549

© 2011 MAT Industries, LLC. All Rights Reserved. Tous droits réservés. Reservados todos los derechos.
ProForce ® is a registered trademark of / sont des marques déposées de / son marcas comerciales registradas de /
MAT Industries, LLC, Long Grove, IL 60047.
Product style and configuration may vary. La configuration et le style du produit peuvent varier. El estilo y la
configuración del producto pueden variar.